

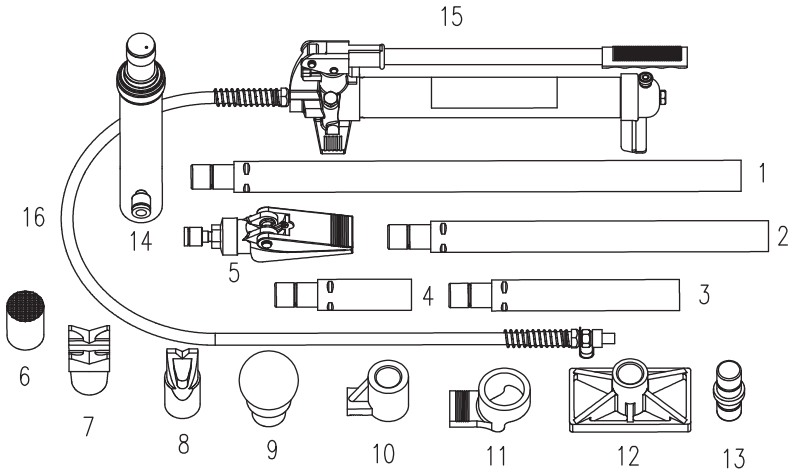

# PARTS BREAKDOWN

NO.	DESCRIPTION	QTY
1	extension bar 1	1
2	extension bar 2	1
3	extension bar 3	1
4	extension bar 4	1
5	spreading wedge	1
6	serrated cap	1
7	"V" base	1
8	cleft cap	1
9	rubber head	1
10	plunger toe	1
11	ram toe	1
12	base plate	1
13	male connector	1
14	ram unit	1
15	10ton pump unit	1
16	hydraulic hose	1

## 10 TON HYDRAULIC BODY REPAIR KIT



# SAFETY INSTRUCTIONS



**PLEASE READ THESE INSTRUCTIONS CAREFULLY. NOTE THE SAFETY INSTRUCTIONS AND WARNINGS. USE THE PRODUCT CORRECTLY AND WITH CARE FOR THE PURPOSE OF WHICH IT IS INTENDED. FAILURE TO DO SO MAY CAUSE DAMAGE TO PROPERTY AND/OR SERIOUS PERSONAL INJURY. PLEASE**

**KEEP THIS INSTRUCTION MANUAL SAFE FOR FUTURE USE.**

**CAUTION: FAILURE TO HEED THE FOLLOWING PRECAUTIONS MAY RESULT IN LOSS OF LOAD, DAMAGE OR FAILURE OF EQUIPMENT, RESULTING IN PROPERTY DAMAGE AND / OR PERSONAL INJURY.**

- Read, understand, and follow all safety precautions and instructions included with the set. If the operator cannot read English, operating instructions and safety precautions must be read and discussed in the operator's native language.
- The owner of this set is responsible for it being installed and operated according to federal , state, and local safety standards.
- Safety-related decals must be installed, maintained, and replaced if they become hard to read.
- Wear eye protection that meets ANSI standards.
- This equipment is designed for vehicle body / frame applications. Using this equipment in an application for which it is not designed could result in overloading, reduced load capacity, reduced stability, and / or system failure.
- Do not overload the hydraulic system; creating pressure beyond the rated capacity of the pump and ram may result in personal injury. Overloading is indicated by bowing extension tubes or slipping attachments.
- Some components in this set do not match the maximum pressure rating of the pump and ram. USE A PRESSURE GAUGE IN THE SYSTEM TO MONITOR HYDRAULIC PRESSURE. Refer to the instructions in this document for Typical Applications and Load Capacities.
- Attachments and extension tubes must be aligned and fully engaged so ram force is straight, avoiding an off center load condition.

# PUMP AND RAM SAFETY INSTRUCTIONS



- Do not exceed the maximum capacity of the pump or tamper with the internal high pressure relief valve. Creating pressure beyond the rated capacity can result in personal injury.
- Completely retract the ram before opening the filler screw on the pump to add hydraulic fluid. An overfill can cause personal injury due to excess reservoir pressure created when rams are retracted.
- Do not exceed the maximum capacity of the ram. Creating pressure beyond the rated capacity can result in personal injury.
- Do not set poorly-balanced or off-center loads on a ram. The load may tip and cause personal injury.



## HOSE SAFETY INSTRUCTIONS

- Before operating the pump, tighten all hose connections using the correct tools. Do not overtighten; connections need only be secure and leak-free. Overtightening can cause premature thread failure or high pressure fittings to split at pressures lower than their capacities.
- Should a hydraulic hose ever rupture, burst, or need to be disconnected, immediately shut the pump OFF, and open the control valve to release all pressure. NEVER grasp a leaking, pressurized hose with your hands; the force of escaping hydraulic fluid could cause serious injury.
- Do not subject the hose to any potential hazard such as fire, extreme cold or heat, sharp surfaces, or heavy impact. Do not allow the hose to kink, twist, curl, or bend so tightly that the fluid flow within the hose is blocked or reduced. Do not use the hose to move attached equipment. Periodically inspect the hose for wear, because any of these conditions can damage the hose and result in personal injury.
- Hose material and coupler seals must be compatible with the hydraulic fluid used. Hoses also must not come in contact with corrosive materials such as creosote-impregnated objects and some paints. Consult the manufacturer before painting a hose. Never paint couplers. Hose deterioration due to corrosive material can result in personal injury.

## OPERATING INSTRUCTIONS

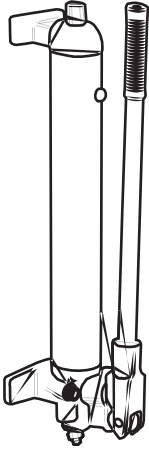

The pump may be operated in a horizontal position, or in a vertical position with the head pointing down as shown.

1. Assemble the hose between the pump and ram.
2. Determine the appropriate attachment for your application; assemble the attachment to the ram piston.

### IMPORTANT:

- The use of extension tubes or off-center attachments greatly reduces the capacity of the hydraulic system. When using extension tubes, put the shortest tubes on the ends of the setup; never put the shortest tubes in the middle of the setup.
- Some components in this set do not match the maximum pressure rating of the pump and ram. **USE A PRESSURE GAUGE IN THE SYSTEM TO MONITOR HYDRAULIC PRESSURE.**

## OPERATING INSTRUCTIONS

1. Turn the pump's release valve clockwise to a closed position. **IMPORTANT:** Hand tighten the valve only; applying too much force to the valve may damage the valve system.
2. Work the pump handle up and down to send oil through the hose to the ram, causing the piston to extend to the work piece.
3. Monitor the pressure gauge while completing the application.  
Note: The pump is equipped with an overload valve that will bypass oil back into the pump reservoir in an overload situation (when the system meets maximum pressure). In this case, continued pumping will have no effect on the system. If an overload situation commonly occurs, a higher capacity set is needed.
4. To release pressure, slowly turn the release valve counterclockwise. (The release speed is controlled by how fast the valve is opened.)

## BLEEDING AIR FROM THE SYSTEM

Air can accumulate in the hydraulic system during the initial setup or after prolonged use, causing the ram to respond slowly or in an unstable manner. To remove the air:

1. Place the ram at a lower level than the pump, with the piston end pointing down.
2. Extend and retract the ram several times without putting a load on the system. Air will be released into the pump reservoir.
3. With the ram fully retracted, the pump sitting level, and no pressure in the hydraulic system, remove the pump's filler screw. Fill the reservoir with approved hydraulic fluid until the fluid level is within 1/2 inch (12.7 mm) from the top of the reservoir.

When offset attachments are used, the rated capacity of the hydraulic system is reduced 50%. For each extension tube used in the setup, the rated capacity is reduced another 50%. When using two or more extension tubes together, always position the shortest tube farthest away from the ram.

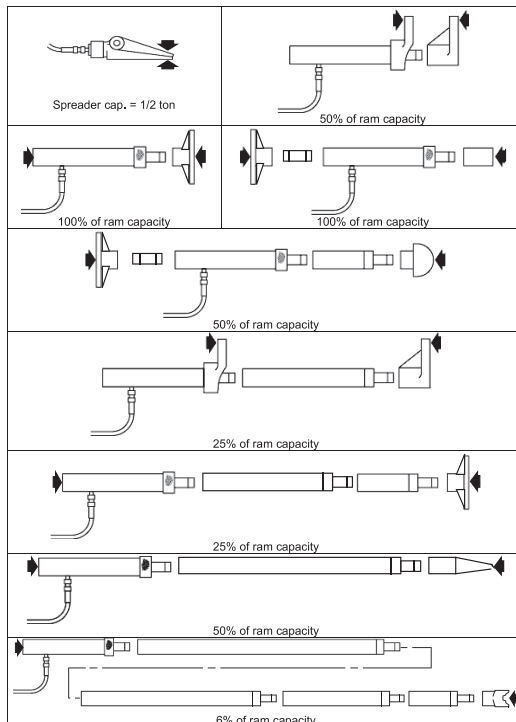



# PARTS LIST

NO.	DESCRIPTION	QTY
1	cylinder	1
2	retainer nut	1
3	protecting cap	1
4	spring	1
5	Nut	1
6	screw	1
7	cir clip	1
8	dust cap	1
9	washer	1
10	Y-ring	1
11	bushing	1
12	O-ring	1
13	ram	1
14	spacing ring	1
15	cir clip	1
16	protecting cap	1
17	screw	1
18	coupling ring	1
19	coupling bolt	1
20	ring	1

## 10 TON HYDRAULIC BODY REPAIR KIT

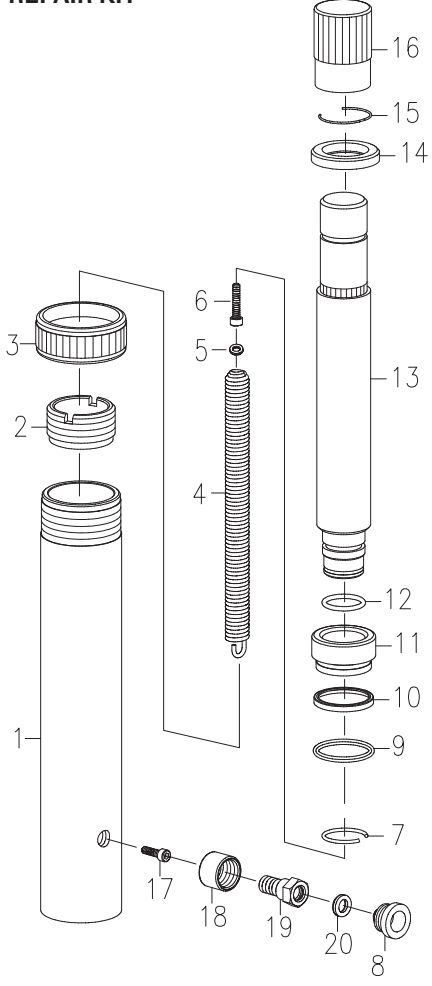

# PARTS LIST

NO.	DESCRIPTION	QTY
1	spring	1
2	cir clip	2
3	pivot pin	1
4	upper duck bill	1
5	lower duck bill	1
6	piston	1
7	washer	1
8	Y-ring	1
9	O-ring	1
10	end cap	1
11	coupling ring	1
12	coupling bolt	1
13	O-ring	1
14	dust cap	1

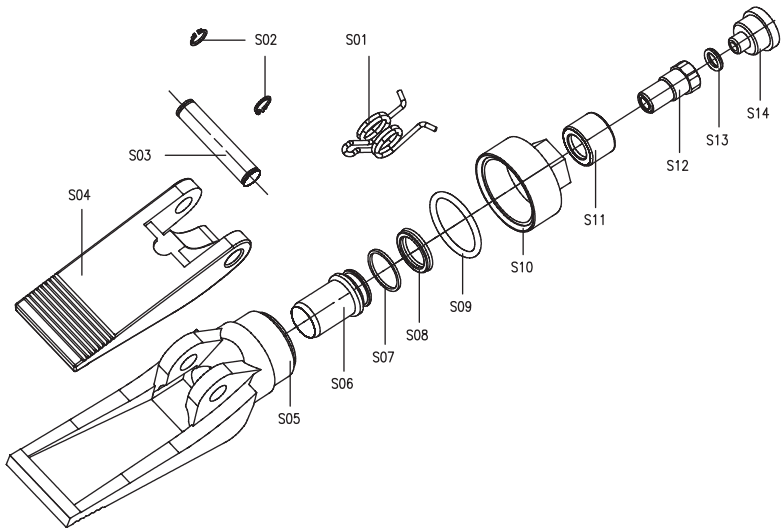

## CARE AND MAINTENANCE

1. When the body repair kit is not in use, the pump unit should be stored with the release valve open.
2. To check oil level, place the pump unit in level position. As indicated on the diagram opposite. Tighten the bleeder screw, if the oil is less, you can add the right amount of oil. Your jack was filled at the factory with high grade hydraulic oil only use approved oil.
3. Must tighten the bleeder screw for release air out before using. Close the bleeder screw when using.
4. After extensive use, the oil supply should be replaced to ensure longer equipment life. To drain remove the bleeder screw and open release valve. Ensure that no dirt gets into the system. Refill with approved jack oil, as paragraph 2.

# TROUBLESHOOTING

CAUTION: TO PREVENT PERSONAL INJURY, RELEASE PUMP PRESSURE AND DISCONNECT THE HOSE FROM THE PUMP BEFORE MAKING REPAIRS.

Repairs must be performed in a dirt-free environment by qualified personnel who are familiar with this equipment. If the following solutions do not remedy the problem, take the product to an authorized service center for repair.

Problem	Cause	Solution
Pump loses pressure	1. System components leaking.	1. Repair or replace as necessary.
Pump not delivering fluid	1. Low fluid level in reservoir. 2. Seats are worn.	1. Check fluid level. 2. Repair seats or replace pump body.
Pump handle has a "spongy" feel	1. Air trapped in system. 2. Too much fluid in reservoir.	1. Refer to Bleeding Air from the system. 2. Check fluid level.
Ram piston will not extend	1. Loose couplers. 2. Low fluid level in pump reservoir. 3. Ram seals leaking.	1. Tighten couplers. 2. Fill and bleed the system. 3. Replace worn seals. Look for excessive contamination or wear.
Ram piston extends only partially	1. Low fluid level in pump reservoir. 2. Load is above capacity of system.	1. Fill and bleed the system. 2. Use correct equipment.
Ram piston extends slower than normal	1. Loose couplers. 2. Restricted hydraulic line or fitting. 3. Pump not working correctly. 4. Ram seals leaking.	1. Tighten couplers. 2. Clean and replace if damaged. 3. Repair or replace as necessary. 4. Replace worn seals. Look for excessive contamination or wear.
Ram does not hold pressure	1. Leaky connection. 2. Ram seals leaking. 3. Pump or valve not working correctly.	1. Clean, reseal with thread sealant, and tighten connection. 2. Replace worn seals. Look for excessive contamination or wear. Replace contaminated fluid. 3. Repair or replace as necessary.
Ram leaks hydraulic fluid	1. Worn or damaged seals. 2. Loose connection.	1. Replace worn seals. Look for excessive contamination or wear. Replace contaminated fluid. 2. Clean, reseal with thread sealant, and tighten connection.
Ram will not retract or retracts slower than normal	1. Pump release valve closed. 2. Loose couplers. 3. Blocked hydraulic lines. 4. Weak or broken retraction springs. 5. Ram damaged internally. 6. Pump reservoir too full.	1. Open pump release valve. 2. Tighten couplers. 3. Clean and flush lines. 4. Send to service center for repair. 5. Send to service center for repair. 6. Drain fluid to correct level.

